

Items Supplied >

- 1 – FRONT MUFFLER ASSEMBLY
- 1 – REAR MUFFLER ASSEMBLY
- 4- 1/4" X 3/4" HEX FLANGED BOLTS

NOTE: MUFFLER INLET GASKETS CANNOT BE REUSED. NEW GASKETS (HD PN# 65900017) MUST BE PURCHASED BEFORE INSTALLATION.

Application >

HARLEY SOFTAIL:	
FXBB STREET BOB	2018
FXLR LOW RIDER	2018
FLSL SLIM	2018
FXBR/FXBRS BREAKOUT	2018
FLFB/FLFBS FATBOY	2018

Instruction Manual >

6047B

Page 1 of 2

*****NOTE: MUFFLER INLET GASKETS CANNOT BE REUSED. NEW GASKETS (HD PN# 65900017) MUST BE PURCHASED BEFORE INSTALLATION.*****

Read all instructions carefully and completely before installing your new slip-on mufflers.

1. Remove the front (lower) muffler first. Loosen the muffler clamp and remove the two bolts on the muffler mount. Then slide the muffler backward off of the headpipe. Save the muffler clamp as it will be reused.
2. Remove the rear (top) muffler the same way. **NOTE:** If you cannot get the proper wrench to remove the rear (top) bolts from the muffler mount bracket then remove the muffler and muffler mount bracket together as a unit by removing the lower two bolts on the muffler mount bracket. See **Figure 1**. Once the muffler and bracket have been removed from the motorcycle then detach the muffler from the bracket. Save the muffler clamp as it will be reused.



REMOVE MUFFLER BRACKET BOLTS TO REMOVE MUFFLER AND BRACKET TOGETHER.

FIGURE 1

3. If the muffler mount was removed then install the muffler mount back onto the motorcycle. Snug the bolts but **do not tighten** at this time.
4. Position the stock clamps with hex head as shown in **Figure 2** and slide them onto the slip-on mufflers.
5. Install new muffler inlet gaskets into the muffler inlets. See **Figure 2**. **NOTE:** MUFFLER INLET GASKETS CANNOT BE REUSED. NEW GASKETS (HD PN# 65900017) MUST BE PURCHASED BEFORE INSTALLATION.

MUFFLER WITH LOGO IS REAR (TOP) MUFFLER

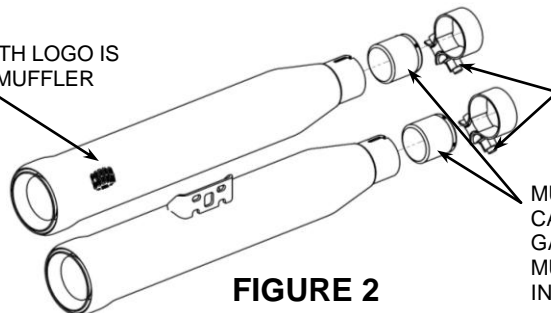

ORIENT STOCK CLAMPS WITH HEX HEAD AS SHOWN

MUFFLER INLET GASKETS CANNOT BE REUSED. NEW GASKETS (HD PN# 65900017) MUST BE PURCHASED BEFORE INSTALLATION.

FIGURE 2

Continued on Page 2

DISCLAIMER: NOT LEGAL FOR SALE OR USE IN CALIFORNIA ON ANY POLLUTION CONTROLLED MOTOR VEHICLES.

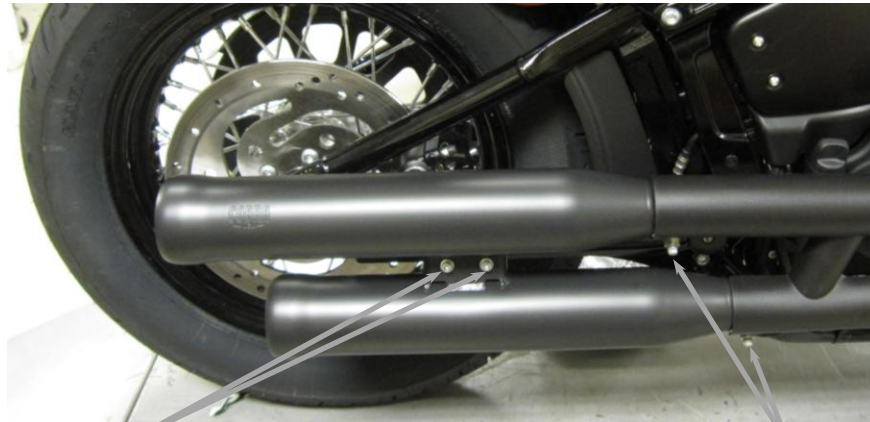

SUPPLIED 1/4" X 3/4"
HEX FLANGED BOLTS

FIGURE 3

STOCK MUFFLER
CLAMPS

NOTE: SOFTAIL STREETBOB SHOWN. MUFFLER POSITION VARIES DEPENDING ON MODEL.

- Slide the rear (top) muffer onto the head pipe first, then the front (bottom) muffer second, until the mounting holes align. See **Figure 3**. **NOTE: THE MUFFLER WITH THE COBRA LOGO IS THE REAR (TOP) MUFFLER.**
- Fasten the mufflers using the supplied 1/4" x 3/4" hex flanged bolts in the same manner as stock but **do not tighten**. See **Figure 3**. Verify that the gap, where the mufflers meet the stock heat shields, is similar to the gap the stock mufflers allotted.
- Adjust the muffer mount bracket up or down so the mufflers are straight on the bike and then tighten the two bolts on the muffer mount bracket. Tighten to factory specifications.
- Check all clearances and alignments then tighten the clamps. (**NOTE:** The muffer clamps should be flush with the end of the muffer when tightened. See **Figure 4**. If the muffer clamps are slid backward past the slots on the muffer slip the clamps will not tighten the mufflers properly).
- Tighten the mounting bolts to factory specifications.
- IMPORTANT:** Before starting your engine remove all fingerprints from all exhaust surfaces. To clean your black exhaust system use a liquid based soap detergent, such as dishwashing soap applied with a soft cloth and rinse with clean water. **Note:** Avoid abrasive cleaning methods such as granular or dry cleansers, simple green, scotch-brite or steel wool pads. Abrasives may breach the coating and shorten life.
- Check the tightness of the button head bolts securing the core/tip to each muffer after the first ride, 100 miles, and every 500 miles after that.

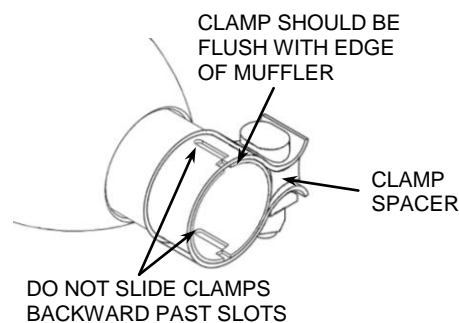

FIGURE 4

DISCLAIMER: NOT LEGAL FOR SALE OR USE IN CALIFORNIA ON ANY POLLUTION CONTROLLED MOTOR VEHICLES.