

Items Supplied >

- 1 – RIGHT MUFFLER ASSEMBLY
- 1 – LEFT MUFFLER ASSEMBLY

Application >

HARLEY:
DRESSER 1995-2016

Instruction Manual >

6206

Page 1 of 1

Read all instructions carefully and completely before installing your new slip-on mufflers

1. Remove the saddlebags carefully.
2. Remove and save the mounting hardware securing the mufflers to the brackets. Loosen the stock muffler clamps then pull the stock mufflers free from the headpipes. Save the stock clamps because they will be reused.
3. Slide the stock clamps over the slip-on mufflers and position them as shown in Figure 1 with the hex head facing inward and towards the ground.
4. Slide the mufflers onto the headpipes until the mounting holes align. **NOTE:** The right muffler will be stamped with a part number on the bracket ending in an "R" and the screws that hold the tip on should be facing inward. Fasten the mufflers using the stock mounting hardware in the same manner as stock but **do not tighten**.
5. From the rear, rotate the mufflers as needed so they are level with the ground and parallel with each other.
6. Verify that the gap, where the mufflers meet the stock heatshields, is similar to the gap the stock mufflers allotted.
7. Check all clearances and alignments then tighten the mounting bolts to factory specifications. Tighten the muffler clamps. (NOTE: The muffler clamps should be flush with the end of the muffler when tightened. See **Figure 2**. If the muffler clamps are slid forward past the slots on the slip collar the clamps will not tighten the mufflers properly. Also, make sure the clamp spacer is not over the slots. The slots need to be covered by the clamp band so that it seals the slots properly. Rotate the clamp if necessary).
8. Reinstall saddlebags carefully.
9. **IMPORTANT:** Before starting your engine remove all fingerprints from chrome with a quality wax or chrome polish. Failure to do so can cause chrome discoloration. Due to fluctuations in fuel delivery settings, timing, etc., Cobra Engineering does not warrant against chrome discoloration. Clean the black exhaust tips with a mild dishwashing soap and a soft cloth. Avoid abrasive cleaning methods such as granular or dry cleansers, simple green, scotch-brite or steel wool pads. Abrasives may breach the coating and shorten life.

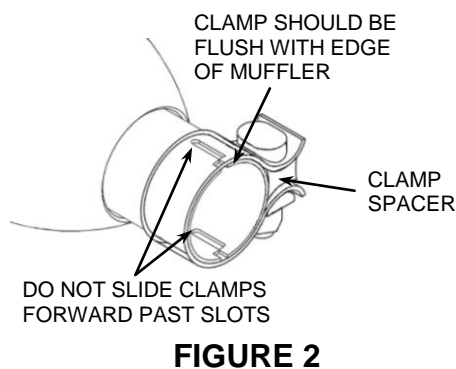
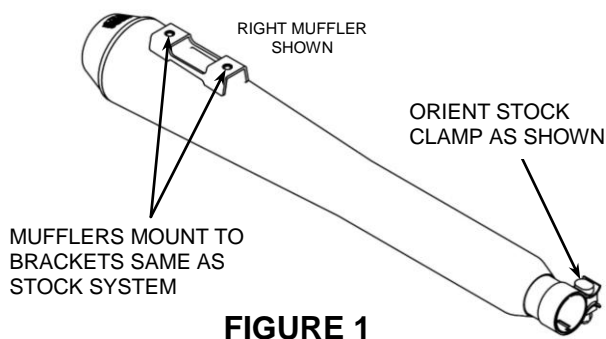

California does not allow the use of aftermarket exhaust systems that remove original equipment catalysts, (except for racing use only) unless the Air Resources Board has issued an Executive Order for that system.

* **Cobra® recommends you always wear a helmet while riding. Please never operate your motorcycle while under the influence of alcohol and/or drugs. Enjoy the new look of your motorcycle and please ride safely.**