

Items Supplied >

1 - INTAKE COVER ASSEMBLED
1 - K&N® VENTURI AIR FILTER
1 - MOUNTING PLATE
1 - BILLET VELOCITY STACK
1 - THROTTLE BODY COVER
2 - INTAKE GASKET
2 - BREATHER BOLT, 3/8"-16 X 1" W/ TEFLON SEALANT
3 - BOLT, 1/4"-20 X 1-1/8", BUTTONHEAD W/ LOCK PATCH
3 - LOCK WASHER, 1/4" TOOTHED
2 - BOLT, 1/4"-20 X 1/2", BUTTONHEAD W/ LOCK PATCH
3 - BOLT, 1/4"-20 X 2-3/4", 12-POINT HEAD W/ LOCK PATCH

3 - SPACERS

Application(s) >

HARLEY:
DRESSER

17-19

NOTE: DOES NOT FIT CVO MODELS.

Instruction Manual >

606-0101-05/05B/05BC/05CB

Page 1 of 3

Read all instructions carefully and completely before installing your new RACE PRO™ Intake.

1. Remove the allen bolt from the center of the stock air cleaner and remove the cover. Remove the (3) bolts securing the filter to the throttle body and remove the filter and breather hose assembly. Save the stock breather hose assembly as this will be reused. Remove the two breather bolts from the cylinders and remove the back cover.
2. Install the supplied breather bolts into the cylinders. See **FIGURE 1**. Tighten securely.
3. Insert the center hose of the stock breather hose assembly through the hole in the supplied mounting plate and then through the velocity stack so that the hose is in the center of the velocity stack. See **FIGURE 1 & 2**.
4. While holding that assembly together with one hand, Insert the (3) supplied 1/4"-20 x 1-1/8" buttonhead bolts and lock washers through the mounting holes in the velocity stack and mounting plate. See **FIGURE 1**.
5. Then align the supplied gaskets and spacer so the notch is to the bottom left and slide them over the (3) bolts onto the backside of the mounting plate. Make sure there is a gasket on both sides of the spacer. See **FIGURE 1**.
6. Align all the components with the throttle body and start threading the (3) buttonhead bolts into the throttle body. Tighten the three bolts evenly making sure the inner diameter of the velocity stack, gaskets, and spacer align with the inner diameter of the throttle body.
7. Attach the stock breather hoses to the breather bolts in the cylinder head. The front hose has to go behind the mounting plate to be attached to the breather bolt.
8. Install the throttle body cover using the (2) 1/4-20 X 1/2" button head screws as shown in **FIGURE 1 & 2**.
9. Place the supplied K&N® filter onto the velocity stack.
10. Place the RACE PRO intake cover over the air filter so that there is a 12-point bolt centered between the top two mounting holes. See **FIGURE 3**.
11. Insert the 2-3/4" long 12-point bolts through the 3 outer holes in the intake cover and through the spacers to the base mounting plate threaded holes. See **FIGURE 3**. Snug the (3) bolts evenly until the intake cover tightens down onto the spacers. Then tighten the bolts securely.
12. Verify all the bolts are tight and then wipe off any fingerprints with a clean microfiber cloth.

CONTINUED ON PAGE 2

DISCLAIMER: NOT LEGAL FOR SALE OR USE IN CALIFORNIA ON ANY POLLUTION CONTROLLED MOTOR VEHICLES.

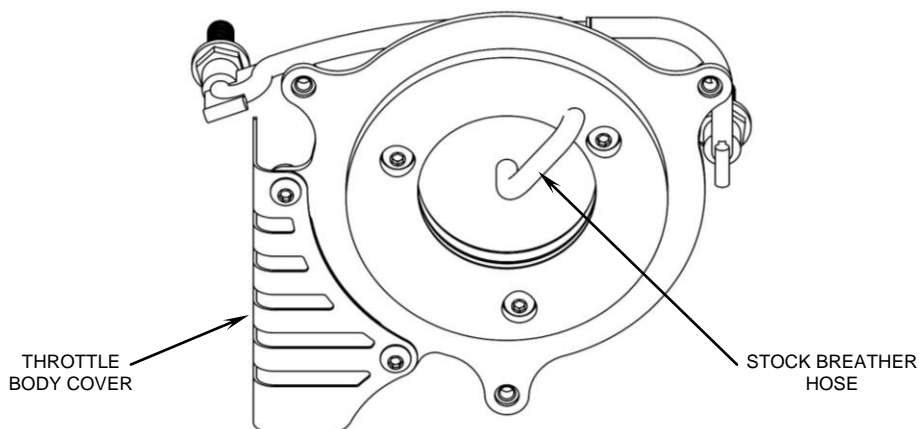
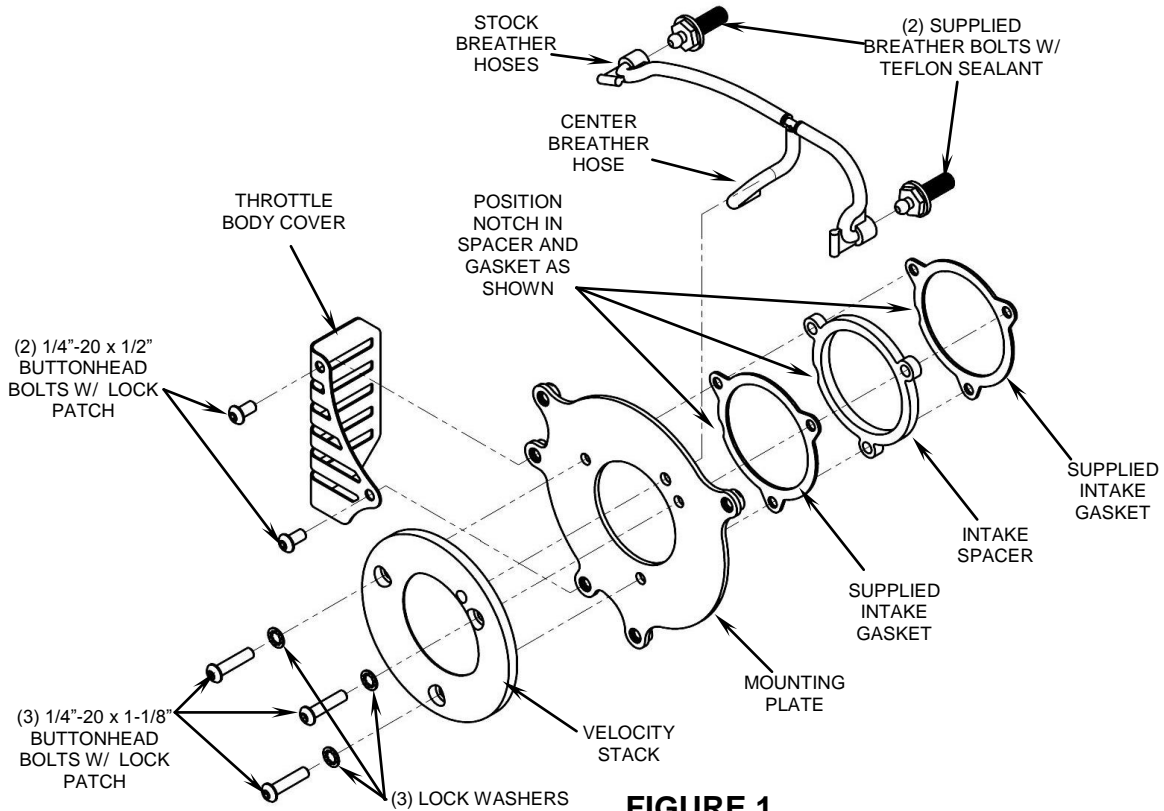

CONTINUED ON PAGE 3

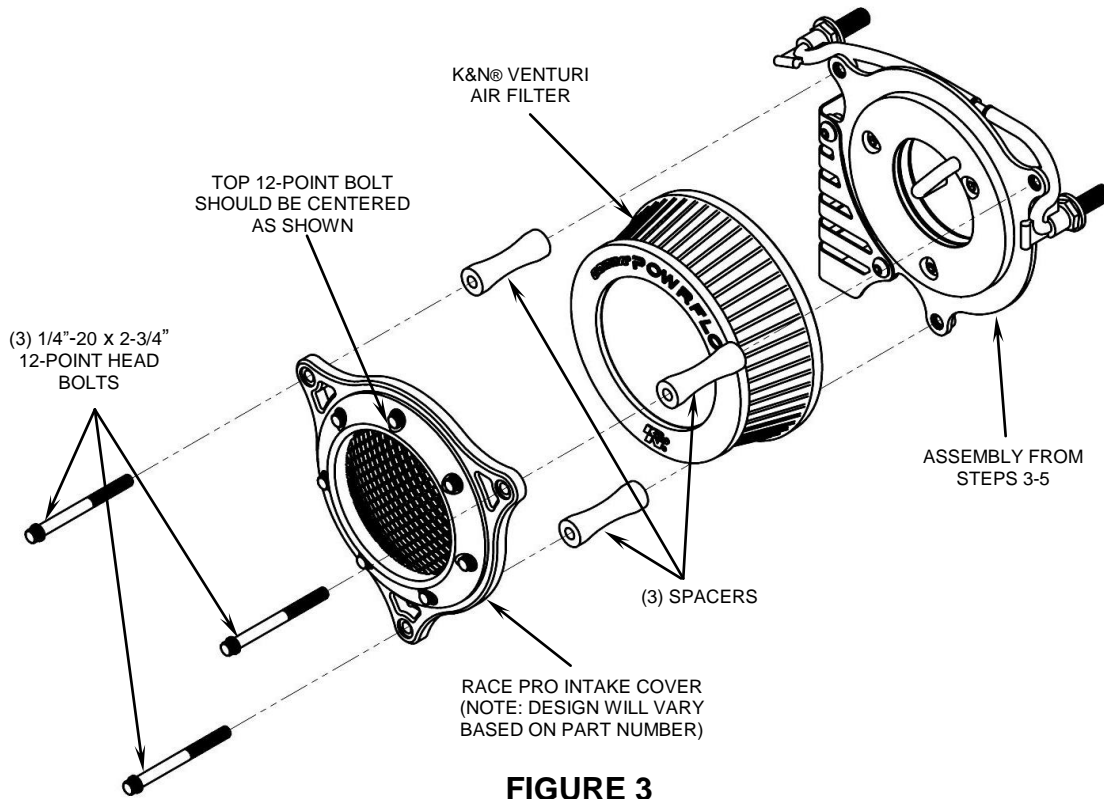

CLEANING INSTRUCTIONS:

To clean any black portions of the RACE PRO air intake system use a liquid based soap detergent, such as dishwashing soap applied with a soft cloth and rinse with clean water. Note: Avoid abrasive cleaning methods such as granular or dry cleansers, simple green, Scotch-Brite or steel wool pads. Abrasives may breach the coating and shorten life.

DISCLAIMER: NOT LEGAL FOR SALE OR USE IN CALIFORNIA ON ANY POLLUTION CONTROLLED MOTOR VEHICLES.

DOCUMENT NO. 0018 REV. B