

Items Supplied >

- 1 - INTAKE COVER
- 1 - K&N® VENTURI AIR FILTER
- 1 - INTAKE SCREEN ASSEMBLY
- 1 - BILLET VELOCITY STACK
- 1 - MOUNTING PLATE
- 1 - SUPPORT BRACKET
- 3 - BOLT, 1/4"-20 X 5/8", HEX FLANGE
- 3 - BOLT, M5 x .8 X 16mm ALLEN W/ LOCK PATCH
- 1 - BOLT, M6 x 1.0 X 10mm, HEX FLANGE (8mm HEAD)
- 1 - BOLT, M6 x 1.0 X 10mm, HEX FLANGE (10mm HEAD)
- 3 - WASHER, #10 SPLIT LOCK
- 1 - SPACER, ALUMINUM M6 x 1.0 THREADED
- 1 - FILTER, BREATHER

Application(s) >

HONDA VTX1300C	04-09
VTX1300R/S	03-09
VTX1300T	08-09

Instruction Manual >

06-0137

Page 1 of 2

Read all instructions carefully and completely before installing your new POWRFLO™ Intake.

1. Remove the seat. Remove the hex bolt at the rear of the fuel tank. Prop the rear of the fuel tank up 2 - 3 inches with a block of wood to allow access to intake. Do **NOT** remove gas lines and be careful not to scratch or drop tank, assistance may be needed.
2. Remove the (5) bolts that secure the stock air cleaner chromed cover. Remove the cover and the stock air filter. Remove the hex bolt from the lower portion of the air cleaner housing. (NOTE: The rubber coated nut that secures the hex bolt may need to be held in place with pliers, to prevent from rotating.)
3. Loosen the (3) phillips-head screws around the carburetor to remove the air cleaner housing from the carburetor.
(NOTE: Carefully rotate the air cleaner housing outwards from the bottom to disengage the intake snorkel that resides under the fuel tank. Assistance may be needed to further lift the gas tank for clearance.)
4. On the backside of the air cleaner detach the two rubber hoses by squeezing the hose clamps with a pair of pliers and sliding them past the hose inlets. Disconnect the idle adjuster and leave hanging for now.
5. Use the (1) supplied M6 x 10mm hex flange bolt (with 8mm head) to attach the support bracket to the backside of the mounting plate. Snug the bolt into the threaded insert but do not tighten. See Figure 1.
6. Insert the supplied breather filter into the larger hose that was disconnected in Step 4 and secure with the stock hose clamp. See Figure 2 for position.

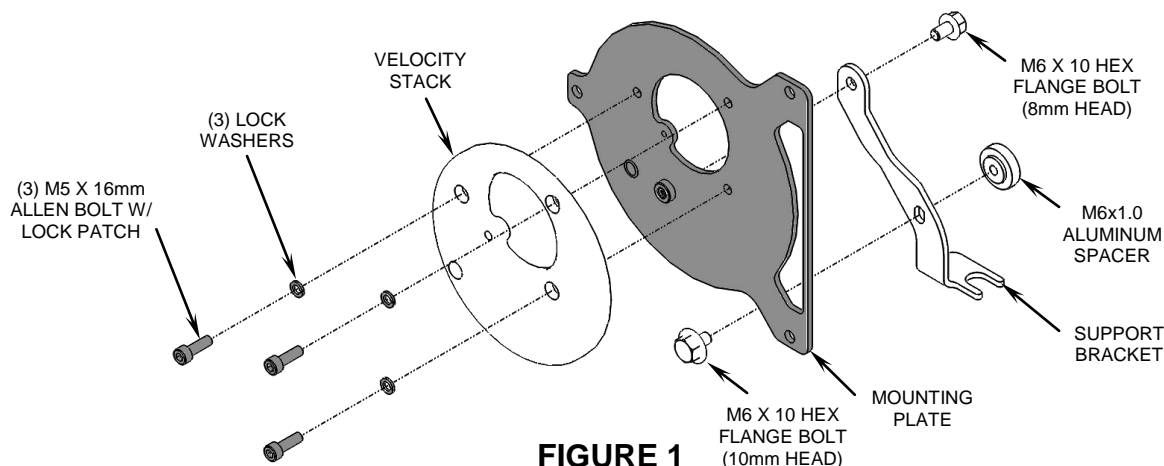
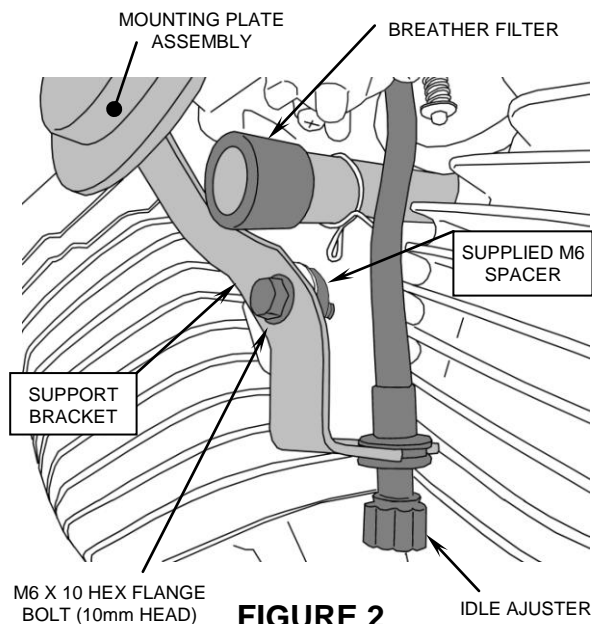
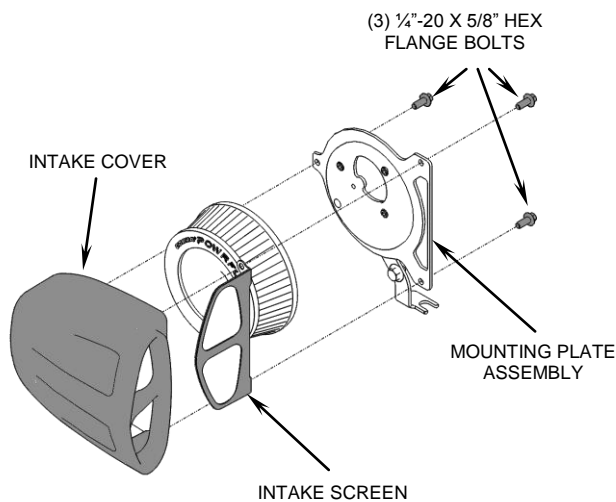

FIGURE 1

* Cobra® recommends you always wear a helmet while riding. Please never operate your motorcycle while under the influence of alcohol and/or drugs. Enjoy the new look of your motorcycle and please ride safely.

7. Reroute and attach the smaller hose and hose clamp that was disconnected in Step 4, to the inlet tube on the backside of mounting plate.
8. Using the (3) supplied M5 X 16mm allen bolts and lock washers, attach the velocity stack and mounting plate (with support bracket) to the carburetor in the order shown in Figure 1. Fully tighten the allen bolts.
9. Align the installed support bracket with the bracket between the cylinder heads. Insert the (1) supplied M6 x 10mm hex flange bolt (with 10mm head) through the support bracket, cylinder bracket and thread into the supplied M6 aluminum spacer. See Figure 1 and Figure 2. Make sure the small diameter boss on the aluminum spacer is fully engaged into the hole on the backside of the cylinder bracket, then tighten.
10. Now fully tighten the M6 x 10mm hex flange bolt (with 8mm head) securing the support bracket to the mounting plate. (NOTE: tightening bolt may be difficult due to tight working area).
11. Attach the idle adjuster to the support bracket retaining tab. See Figure 2.
12. Place the supplied K&N® filter onto the velocity stack.
13. Remove the intake cover from the box and insert the intake screen into place so the holes in the bent tabs align with the threaded bosses in the intake cover.
14. Place intake cover over the mounting plate assembly and align the mounting holes to the threaded bosses. Insert the (3) supplied 1/4"-20 x 5/8" hex flange bolts and tighten the mounting plate to the intake cover. See Figure 3.
15. Lower the fuel tank back into place and secure with original bolt and washer install seat and secure properly.
16. Check that all bolts and clamps are properly secured and sealed before starting motorcycle.

**FIGURE 2****FIGURE 3****CALIFORNIA CUSTOMERS:**

In California, aftermarket parts that have been identified specifically as replacement parts or that have received an Air Resources Board Executive Order may be used on street motorcycles. All other emissions related aftermarket parts are for competition use only. A list of replacement parts and EO parts, and corresponding fitment is provided at: www.cobrausa.com