

PARTS LIST

Index	Description	Qty.
1	Windshield	1
2	Bracket Left	1
3	Bracket Right	1
Bag 350		
4	Screw, Hex M8 x 45mm	2
5	Nut Whizlock M8 x 1.25	2
6	Face Plate	2
7	Wellnut	4
8	Screw, Trus, 10-32 x 5/8"	4
9	Screw, Carriage, 1/4 -20	2
10	Clamp	2
11	Washer, Flat	2
12	Whizlock Nut 1/4 - 20	2

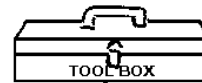
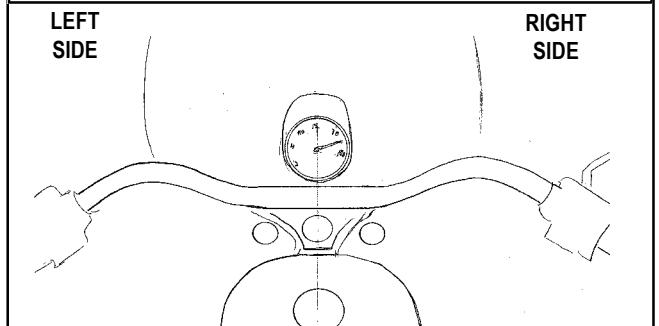

 Phillips Screw Driver
 13mm Wrench
 10mm Wrench / 12mm Wrench

NOTE: Right and Left side of Motorcycle is determined while sitting on the bike.

PREPARATION / INSTALLATION
Note: This product is intended to fit more than one model of vehicle. Installation procedure and adjustment may vary depending on model.

1. Cover front fender.
2. Remove headlight assembly. It is not necessary to disconnect wires. Let assembly hang carefully from bucket.

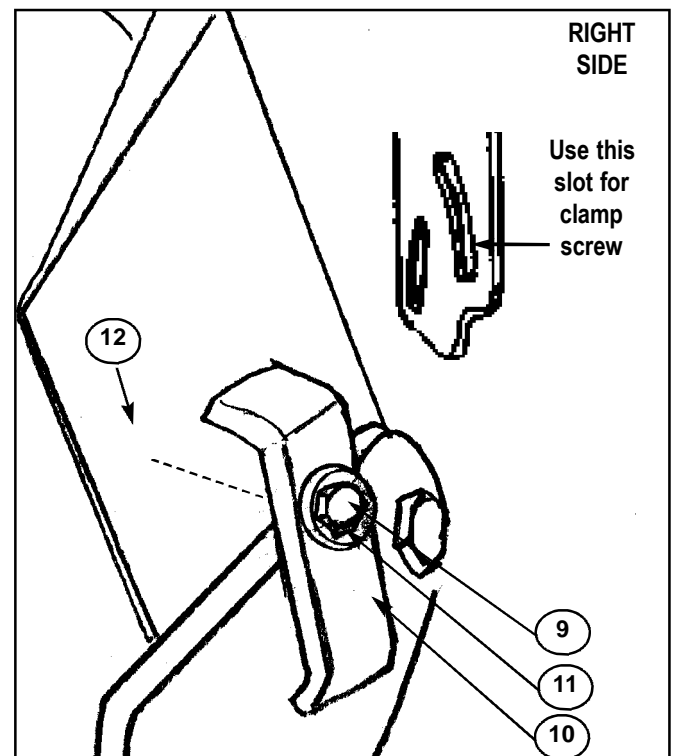
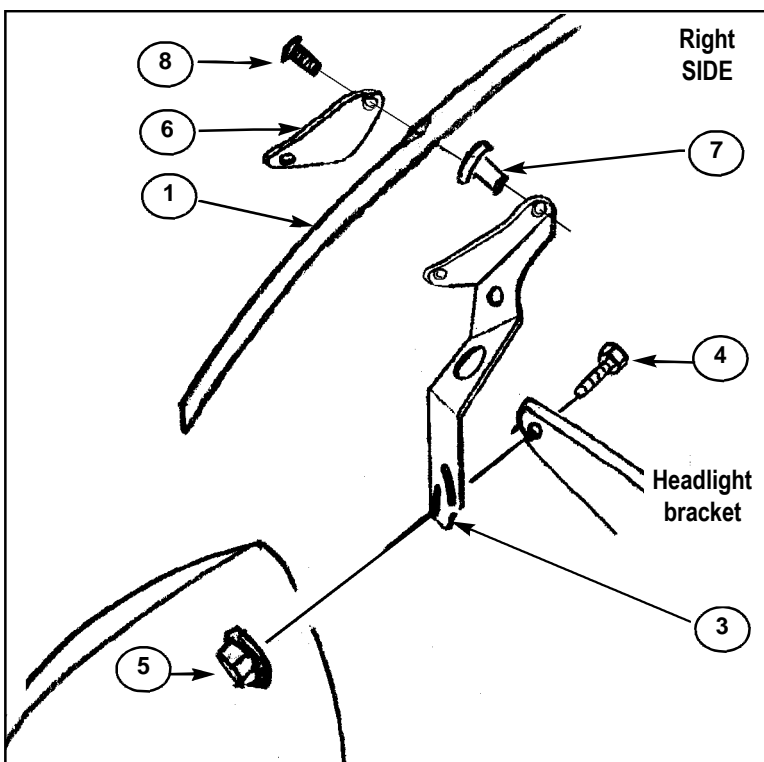
Note: Work one side at a time.

3. Remove headlight mount bolt.
4. Loosely install right side bracket. Repeat steps 3 and 4 for left side.
5. Install weldnuts and windshield to brackets.
6. Adjust Windshield angle.
7. Loosely install clamp. Place washer to the outside of clamp. Make final windshield adjustments. windshield.
8. Tighten all fasteners.



WARNING / MAINTENANCE

WARNING National Cycle windshields and fairings are designed to provide wind protection and increased riding comfort, but not protection in the event of a collision with another vehicle, the road, birds, or any other object.

Our products utilize certain features, patented and otherwise, that may minimize injury in certain accidents, but the possibility of injury exists if the screen is broken or if impacted by an object. Always wear eye protection, helmets and protective clothing. Never ride your motorcycle while under the influence of drugs or alcohol.

All of our products are made in conformance and exceed the requirements of D.O.T. SS205,Z26.1, classifications AS6 and AS7, which covers all safety glazing for motorcycle application. Never ride your motorcycle with loose windshield mounting hardware. Check the hardware for tightness regularly.

Today's motorcycles are built with enough frame rigidity to withstand the moderate loads imposed on them by the foreseeable addition of a fork mounted windshield. If the addition of an accessory(ies) adversely affects your motorcycle's stability, immediately remove the accessory(ies). Do not ride a motorcycle that exhibits unsafe handling traits.

Have experienced service personnel correct any problem before riding with the accessory(ies) installed. For further questions concerning handling problems associated with an accessory(ies), contact your dealer, motorcycle manufacturer, or accessory manufacturer.

MAINTENANCE To clean the screen, wash with a clean soft cloth, plenty of warm water and, if necessary, a non-abrasive soap such as dishwashing liquid. Flannel or soft chamois make good cleaning cloths. Paint, glue residue or grease removal: Moisten cotton with Naphtha or Turpentine followed by a wash as above. Apply a high quality plastic cleaner, such as McGuir's Mirror-Glaze MG-17 or Novus #2, to the screen. This will leave a protective coating in the screen making future cleanings easier.

Do not clean the screen with glass cleaners. Do not use rain protective products on the screen. The solvent action of the alcohol in these products will destroy the screen. Do not allow brake fluid, alcohol, or strong solvents to contact the screen or penetrate between the chrome brackets and the Permanent damage will result! To remove fine scratches, use a very soft clean cloth and a fine grade buffing compound. Jewelers rouge or McGuir's Mirror-Glaze MG-10 are best for this type of buffing. We recommend hand buffing.

STORAGE Do not use low quality vinyl covers or old shower curtains to store your motorcycle or windshield. These products damage the plastic of windshields and the motorcycle body.